



- Compact design
- Maintenance friendly
- High hydraulic efficiencies
- High operation reliability
- Simple installation

Submersible Recirculation Pump Type ABS RCP

Application areas

The submersible recirculation pumps type ABS RCP have been designed for pumping activated sludge in treatment plants during the nitrification and denitrification process, as well as for pumping of storm, surface and river water. As all submersible pumps and submersible mixers from Sulzer they have been designed for economical and reliable operation.

Installation

The submersible recirculation pumps type ABS RCP are supplied with the wellproven automatic coupling system using a single guide rail. The single guide rail coupling system guarantees quick and economical installation.

The DIN-flange of the discharge line (supplied by the customer) forms the connection flange of the automatic coupling unit. A guide rail joins the connection flange with the pipe retainer at the top of the tank. The RCP is connected on to the guide rail and can be lowered easily. It reaches its correct operating position automatically and is immediately ready for use.

- 1 Self-cleaning propeller, 2- or 3-blade, optimized for effective mixing and vibration-free running. Designed to achieve high thrusts
- 2 High efficiency three-phase motor, water pressure-tight encapsulated, protection type IP 68, stator insulation class F = 155°C. Motor shaft and rotor dynamically balanced
- 3 Cable connection area sealed from motor, with water pressure-tight cable inlet, antikink sleeve and strain relief
- 4 Double shaft sealing with medium side mechanical seal of pure sintered silicon carbide
- 5 Hydrodynamically designed solidsdeflection-ring
- 6 DI-electrode for seal monitoring and indication that an inspection is due
- 7 Lubricated-for-life bearings with a calculated life of more than 100,000 operating hours

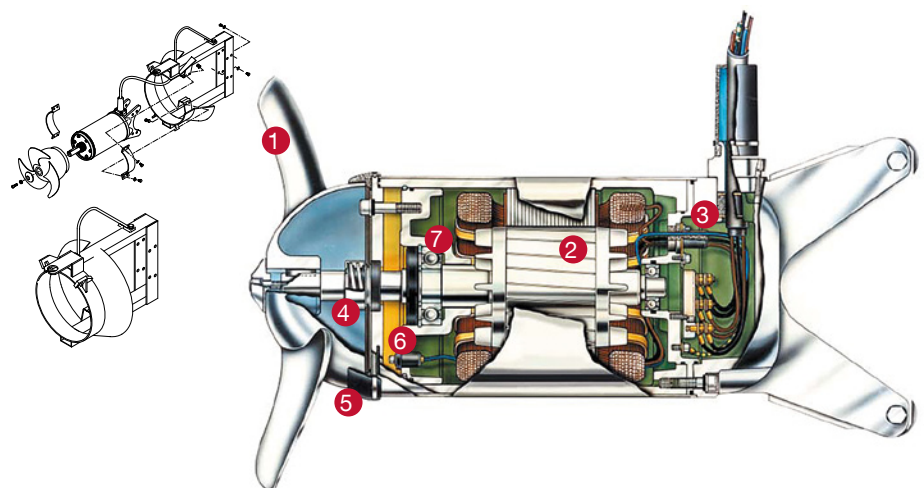

Installation example

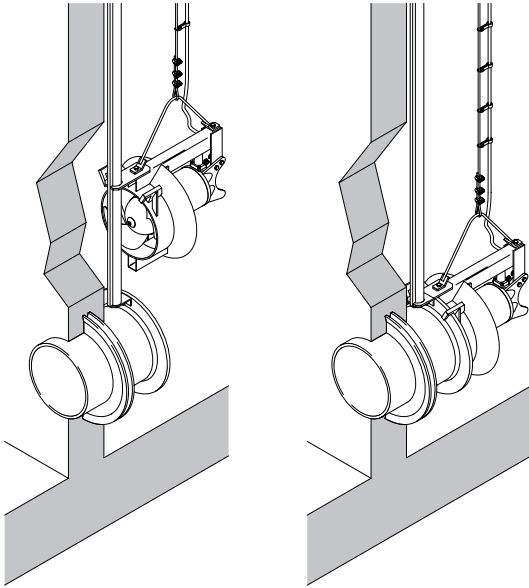

Construction

Available in two standard material versions:

EC cast iron version (Economical)

Motor housing and bracket made of GG-25/GGG-40, propeller and fasteners of motor made of stainless steel.

CR stainless steel version (Corrosion Resistant)

Motor housing made from stainless steel 1.4571, propeller stainless steel 1.4571, fasteners stainless steel 1.4401. Bracket stainless steel.

Valid for the RCP 400, 500 and 800. RCP 250: propeller stainless steel 1.4460.

Technical specifications (50 Hz/60 Hz)

| | |
|---------------|------------------|
| Pipe diameter | DN 250 to DN 800 |
| Motor power | 1.5 - 25 kW |
| Flow max | up to 1,200 l/s |
| Head | up to 2.3 m |

Technical specifications

